

LVD Saturn Lamp

Photometrics

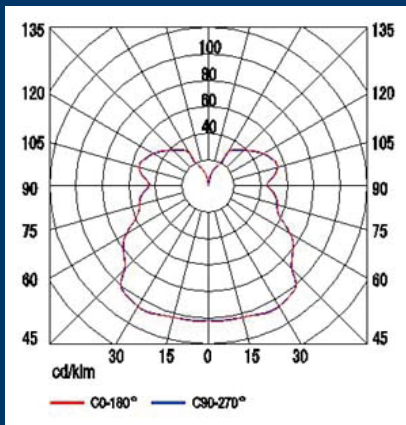

150W Saturn Lamp

Dimensions

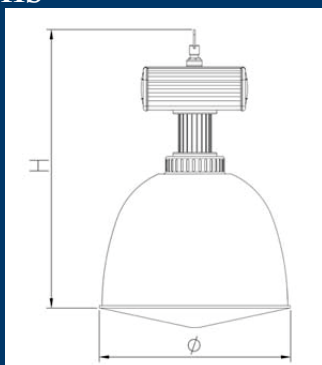

Name: Highbay

Serial Code: 0361-2(19")

Dimension: Φ 495xH685 mm

Wattage: 120W-150W

Package Dimension: 562x562x697 mm

Features:

1. The end covers are made of high pressure die-casting Alu and electrical box is made of Aluminum Alloy Profile.
2. Electrostatic spray surface, perfect appearance.
3. Oxidation and polishing high-purity aluminum reflector, high reflectance and stable optical property.
4. Tempered glass, high light transmission.
5. Can match with our LVD Saturn series lamp with its excellent Color Rendering Index and light efficiency, long life span, no flicker and energy saving, wide range of color temperature and soft light ,stable light output

上海宏源照明电器有限公司
 Shanghai Hongyuan LIGHTING & Electric Equipment Co.,Ltd
 上海市真南路5028号
 No.5028 Zhennan Road

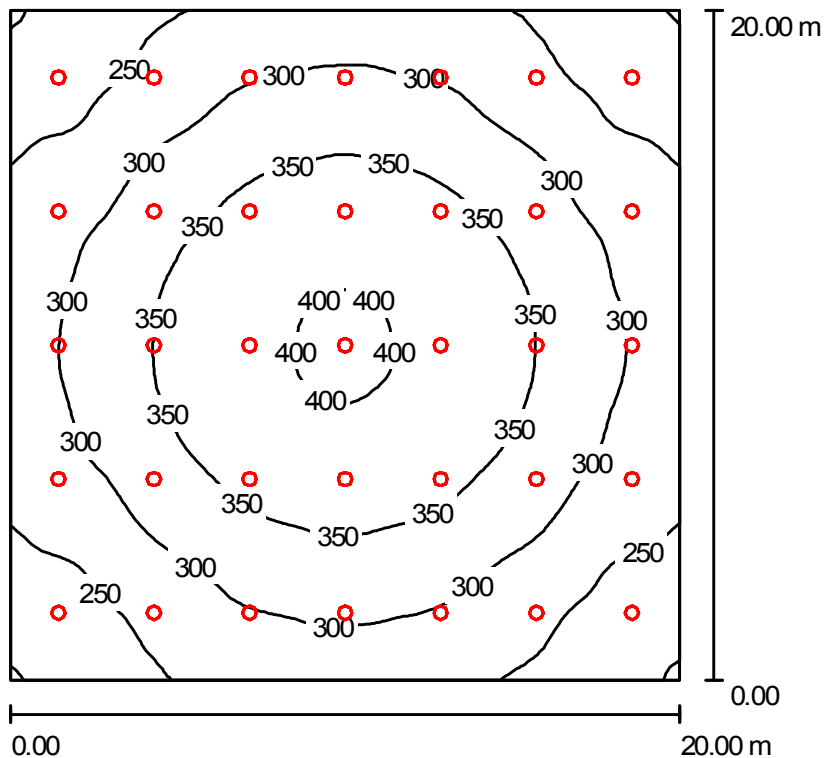

Height of Room: 8.000 m, Mounting Height: 8.000 m, Light loss factor: 0.80

Values in Lux, Scale 1:257

Surface	ρ [%]	E_{av} [lx]	E_{min} [lx]	E_{max} [lx]	u_0
工作面	/	309	198	407	0.640
地板	20	292	192	380	0.659
天花板	70	83	71	115	0.859
Walls (4)	50	226	85	535	/

工作面:
 Height: 0.850 m
 Grid: 64 x 64 Points
 Boundary Zone: 0.000 m

Luminaire Parts List

No.	Pieces	Φ [m]	P [W]
1	35	12000	150.0
		Total:	420000 5250.0

Specific connected load: $13.13 \text{ W/m}^2 = 4.25 \text{ W/m}^2/100 \text{ lx}$ (Ground area: 400.00 m^2)